

Manual for *Stingray X2* tattoo machine rev.1

Patent Pending

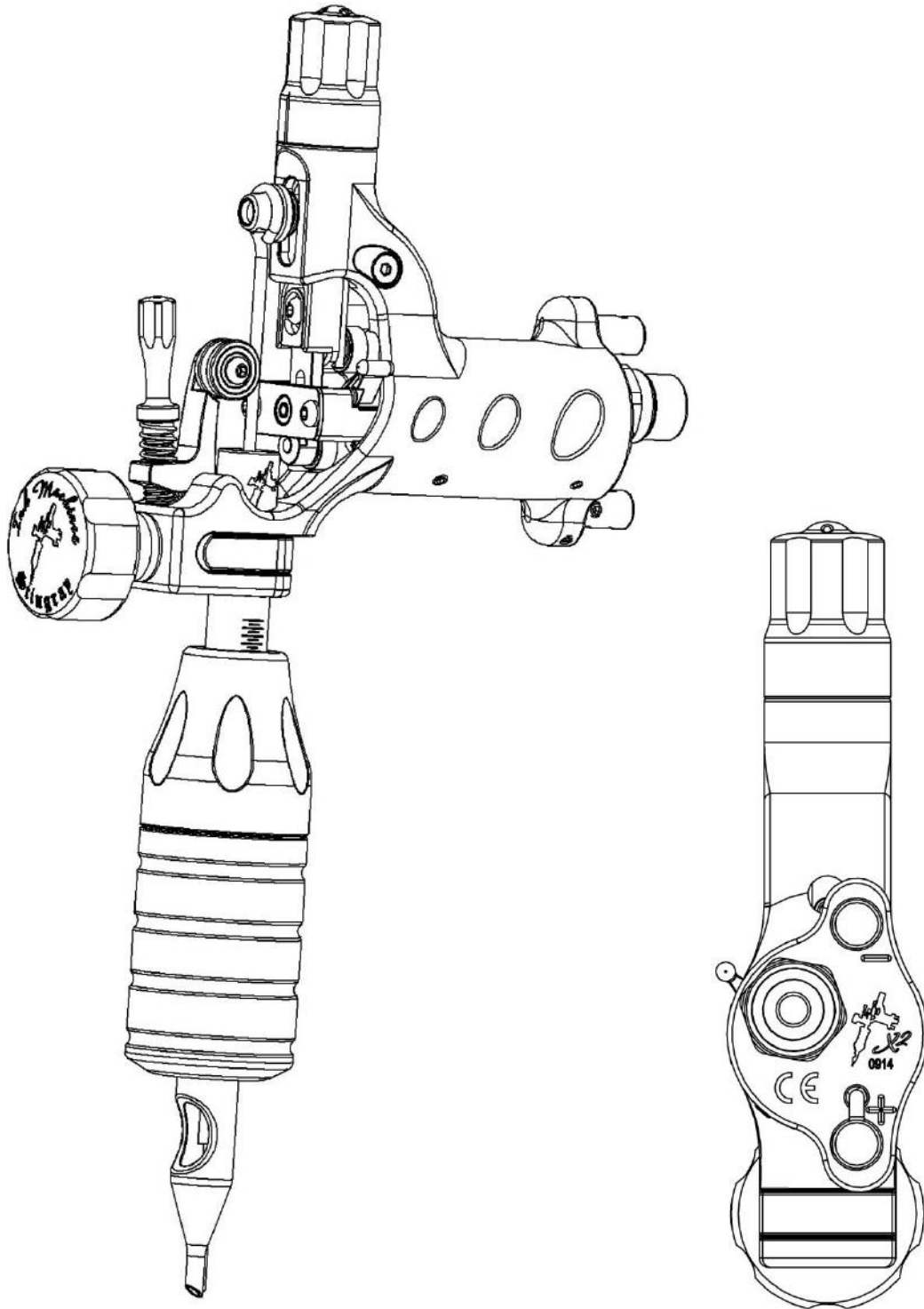

Manufacturer: InkMachines Sweden AB
BOX 8025
350 08 VÄXJÖ, Sweden



Introduction

We are proud to present the evolution of the Stingray machine. The *X2* model is the sum of our experience from building machines during the years and has led to several improvements. Manufactured with the highest quality materials and components available.

Description

The Stingray is a state of the art rotary based Desmodromic cam tattoo machine with features that gives it several advantages compared to other tattoo machine types. The most important advantage is the new Patent Pending Desmodromic roller cam system which gives the unique ability to produce a defined needle motion with full control. Unlike any normal rotary machine or swash drive that has a fixed eccentric motion the Desmodromic cam can produce a 100% controlled linear motion with variable speeds at certain angles of the motor revolution with the motor spinning at a constant rpm.

The Stingrays Desmodromic cam system enables to create a motion that is perfect for lining and color packing like a tuned coil machine but with greater precision and consistency. Not only does the system allow you to change to different stroke lengths but also the ability to totally change the characteristics and behavior of the machine and the needle speed by changing to different cams. Changing the cam is very easy and takes only a few minutes.

Benefits

Besides the obvious that it is light and has a comfortable sound the greatest benefit with the Stingray is that it makes it easier to penetrate difficult areas of the body and loose skin, put the pigment in to the skin more efficiently and cause less damage and better healing.

Like the Dragonfly the Stingray have been tested and developed for over two years by engineers and several professional tattoo artists which means that you can look forward to the reliable and satisfactory performance of the Stingray for years to come.

To ensure safety and obtain maximum service life from the machine it is essential that users read and understand this manual. Check out www.Inkmachines.com for more info and news.

X2 Improvements

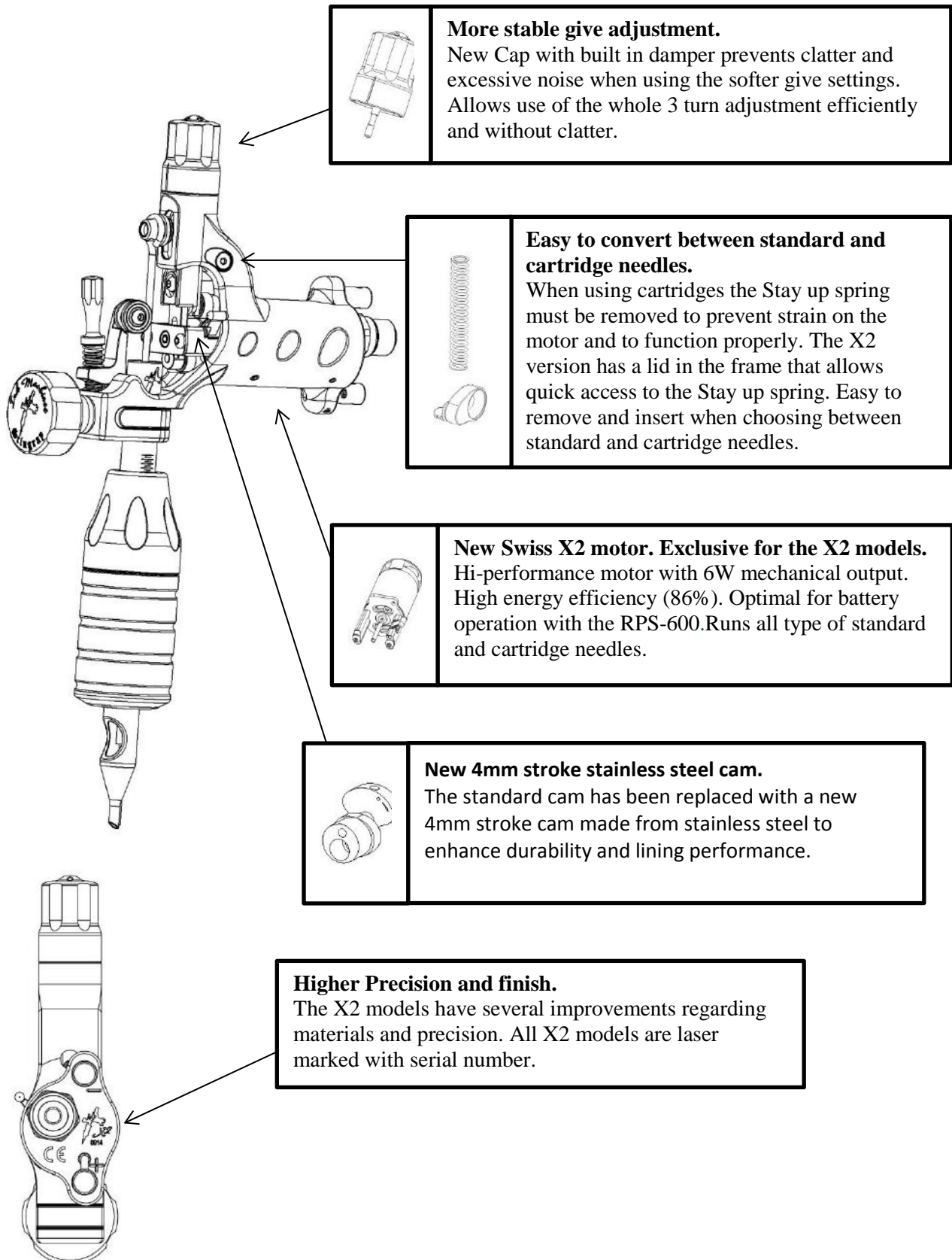

More stable give adjustment.
New Cap with built in damper prevents clatter and excessive noise when using the softer give settings. Allows use of the whole 3 turn adjustment efficiently and without clatter.

Easy to convert between standard and cartridge needles.
When using cartridges the Stay up spring must be removed to prevent strain on the motor and to function properly. The X2 version has a lid in the frame that allows quick access to the Stay up spring. Easy to remove and insert when choosing between standard and cartridge needles.

New Swiss X2 motor. Exclusive for the X2 models.
Hi-performance motor with 6W mechanical output. High energy efficiency (86%). Optimal for battery operation with the RPS-600. Runs all type of standard and cartridge needles.

New 4mm stroke stainless steel cam.
The standard cam has been replaced with a new 4mm stroke cam made from stainless steel to enhance durability and lining performance.

Higher Precision and finish.
The X2 models have several improvements regarding materials and precision. All X2 models are laser marked with serial number.

Safety

The Stingray is designed and developed solely for tattooing of humans by professional tattoo artists. Do not under any circumstances use for other purposes.

InkMachines only provide products for professional tattoo artists and may only be used by professionals with knowledge about diseases and how to maintain a clean working environment and sterile equipment. Work safe!

Always use sterile tubes, grips, tips and needles.

Always use rubber gloves.

Use plastic bags and wraps for tattoo equipment around the machine and the power cord.

Always keep your machines clean! Before and after every use you should: remove any oil or dirt and wipe the machine clean with alcohol or equivalent disinfectant.

The manufacturer does not have responsibility for any kind of material damage, person damage or infection caused by negligence or misuse of the machine or the components attached to the machine.

The manufacturer does not have responsibility for contamination or infection of humans or animals.

Service

Tools and spare parts are available on www.inkmachines.com in the spare parts section if you want to do service work yourself. To properly make service work on your own you will need the **Precision tool kit** ®. You can also send machines to our service technicians for a full service. For more information go to www.inkmachines.com

Warranty

This product includes a 12 month warranty from the date of purchase. The warranty applies to factory faults and not to wear of any components caused by normal or abnormal use.

The warranty is void if:

1. Input Voltage above 14 volts has been applied to the machine.
2. Machine or any of its components have been autoclaved or cleaned in an ultrasonic cleaner.
3. Components have been damaged by misuse or carelessness.
4. Components have been manipulated.

Delivery content

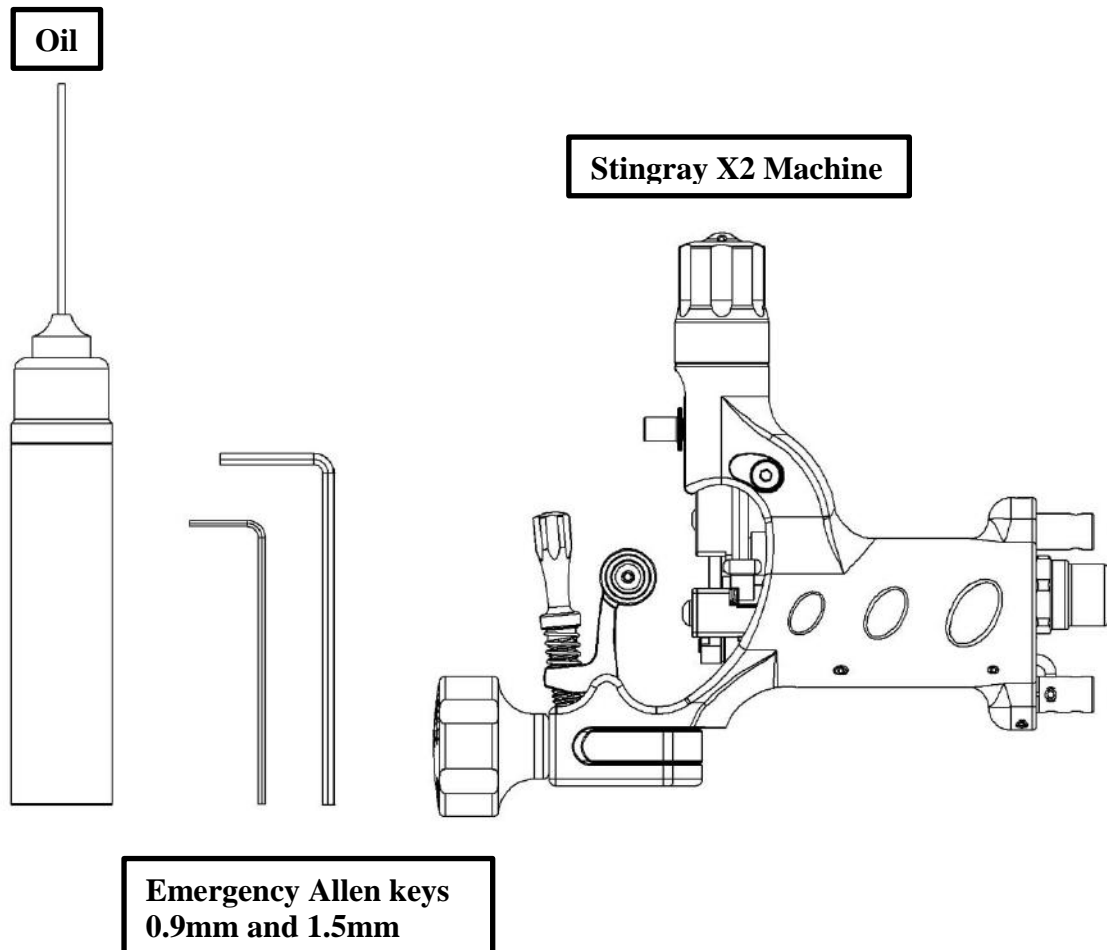

Getting started

1. Disconnect the machine from the power supply.
2. Attach a new quality rubber nipple or grommet to the **Needle bar pin ⑥**. The nipple or grommet should have a tight fit with the Needle bar loop.
3. Open the retainer to make clearance for the needle bar and tube by adjusting the **Retainer screw ④⑤**.
4. Bend the needle bar to a slight arc shape and / or make a bend just at the soldering to compensate the pressure from the needle bar retainer. This enables the needles to work straighter, prevent it from wobbling and making it more stable in the tip.
5. Insert the needle carefully into the tube without damaging the needle tips.
6. Insert the tube / needle assembly trough the **Tube vice clamp ⑤** and tighten the vice lightly. Attach the needle bar loop to the nipple.
7. Move the **Needle bar pin ⑥** and the attached needle bar down to the bottom of its stroke by pressing the needle bar pin downwards, if the needle bar pin won't move down push the **Releaser ⑥②** to release it.
8. Inspect and adjust the protrusion and alignment of the needle and tip by moving the grip and tube to the desired location. Tighten the tube vice firmly when done.
9. Adjust the **Needle bar retainer ④④** by turning the **Retainer screw ④⑤** until the **retainer O-ring ③①** makes contact with the needle bar. Don't tighten more than necessary to keep the needle stable in the tip. If the needle bar don't align properly with the retainer O-ring, adjust / bend the needle bar so that it aligns.
10. Connect the machine to a power supply (max 13 volts DC) either with a RCA cable to the **RCA contact ⑫** or a clip cord to the **Clip cord binding posts ⑩⑪**, if you choose to use a clip cord make sure to connect positive to + and negative to – marked on the machine next to the binding posts. The motor should turn clockwise when looking at the front.
11. Run the machine between 8.5-10 volts depending on needle size and friction, fine adjust the **Needle bar retainer ④④** until the needle feels stable in the tip and make sure that everything runs smoothly without excessive friction or noise.
12. Run the machine and adjust the needle suspension (give) by feeling the **Needle bar pin ⑥** and nipple with your finger and by turning the **Cap ③①** to get the desired hitting, clockwise = harder, counter clockwise = softer. When the cap is turned clockwise to the bottom the **Needle bar pin ⑥** will be locked with the **Piston ②①**. This position will give the hardest hitting. When the cap is turned counter clockwise the stroke will be increasingly softer until the limit is reached. When the limit is reached (about 3.5 turns from the bottom) the **Adjustment screw ⑱** will make contact with the cap from the inside and produce noise, turn the cap clockwise until the adjustment screw clears the cap and the noise stops. If you turn the cap beyond 3.5 turns from the bottom position and the cap should come off, screw down the adjustment screw two turns and reattach the cap by pushing it while moving it in a circular motion until it clicks into place.
13. Encapsulate the machine and cord with plastic bags and wrappings for tattoo equipment.
14. Typical start value would be around 9 volts. The adjustment is normally set to soft for lining and medium to hard for filling / packing color. These are just start values and are very much individual. You may find other settings to suit you better depending on your technique, equipment etc.

X2 Cap

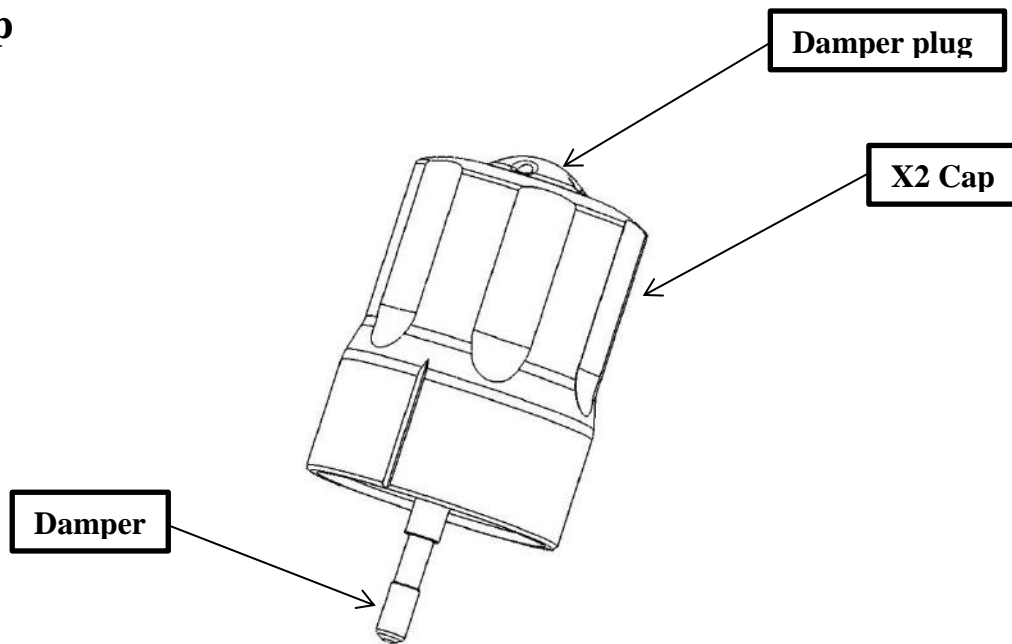

The new X2 cap has a built in Damper that prevents clatter and noise when the give adjustment is used.

Note: The Damper makes the machine slightly louder when running without needles or when the adjustment is set to the hardest setting. When the machine is set up with needles and soft give setting are used the clatter and noise will be greatly reduced compared to running without it.

The Damper has a service life of approximately 1500 hours. The machine can be operated without the Damper if the give adjustment is not required. To remove the Damper from the cap use a pliers and grab the tip of the Damper to pull it out from the Damper plug. Don't grab the shaft of the Damper as it can be damaged. To insert the Damper use the adjustment screw as a guide to locate the hole in the Damper plug. Apply pressure to the damper to insert it firmly.

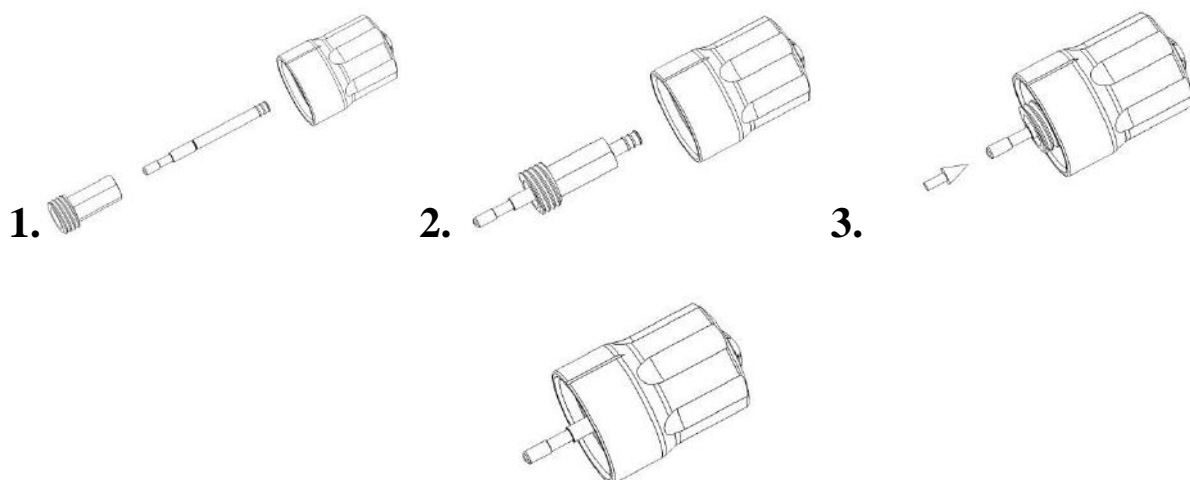

Changing Cams

The Stingray cams can be changed between different variations. Cams are available at inkmachines.com

To properly change the cam and make service work on your own you will need the **Precision tool kit ⑩**. The Stingray X2 is normally delivered with the 4mm steel cam as standard.

Precision tool kit ⑩

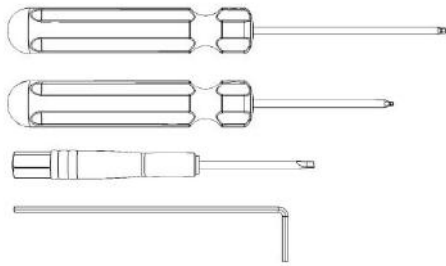

Video also available at [youtube.com](https://www.youtube.com) search word “InkMachines”

1. Remove grip and needle.
2. Remove the **Cap ③ ⑧**
3. Remove the **Shaft support screws ⑥⑩** and the **Rod screw ⑥⑩**.
4. Remove the **Shaft support ⑦④** and the **Rod assembly ⑦③**.

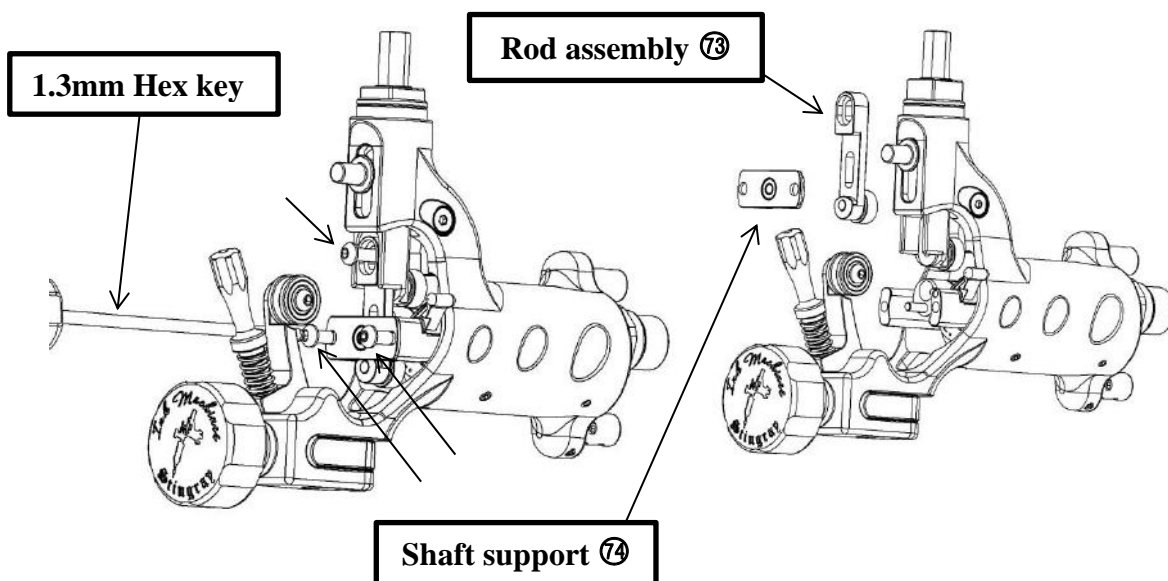

5. Rotate the **Cam** ⑧4 and locate the **Cam screw** ⑮ with a 0.9mm Allen key through the hole in the **Frame** ①. Loosen the **Cam screw** ⑮ and remove the **Cam** ⑧4.

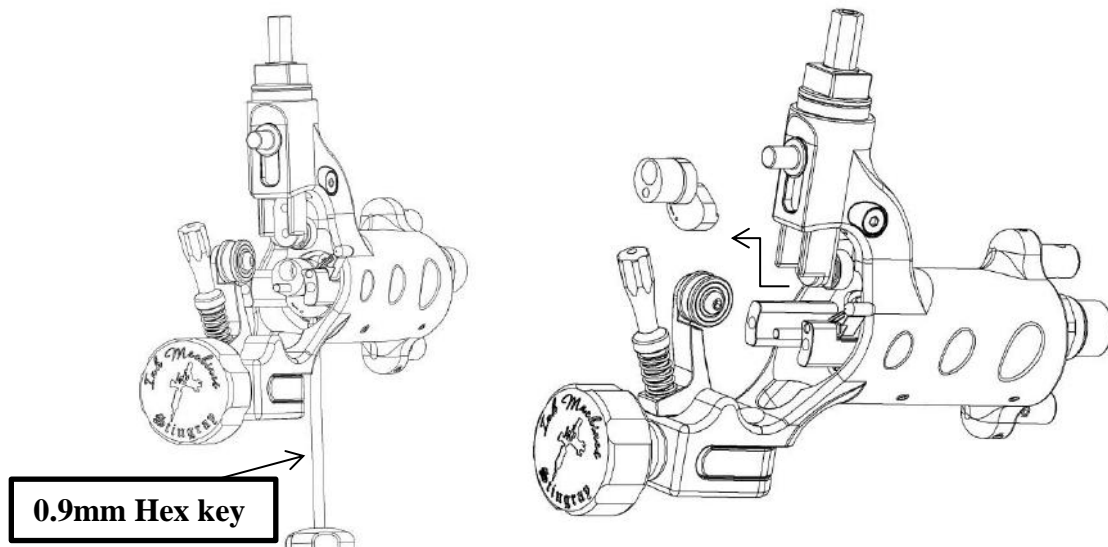

6. Clean the parts and the frame and align the flat part of the motor shaft towards the hole in the frame.
7. Mount the new **Cam** ⑧4 of choice with the **Cam screw** ⑮ downwards so that the **Cam screw** ⑮ and the flat part of the motor shaft align with each other and with the hole in the **Frame** ①. Make sure that the **Cam** ⑧4 is all the way down against the motor and tighten the **Cam screw** ⑮.

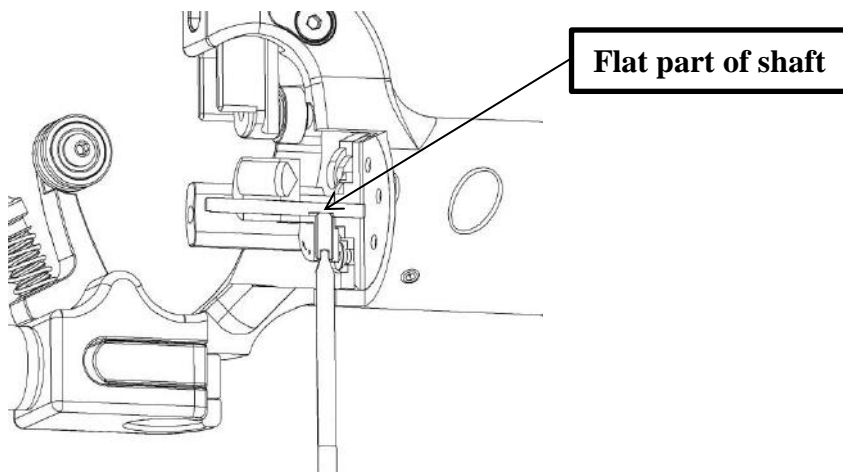

8. Put the **Rod assembly** ⑦3 and the **Shaft support** ⑦4 in place and tighten the **Shaft support screws** ⑥0. The **Shaft support** ⑦4 must be oriented with the clearance groove downwards or the **Rod assembly** ⑦3 won't fit properly.

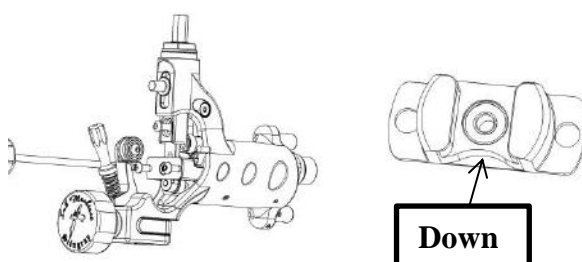

9. Perform lash adjustment. The lash or play between the **Cam bearings** ⑥7 and the **Cam** ⑥4 needs to be adjusted to a minimum. Too much play between the cam bearings and the cam will cause excessive noise and increased wear on the cam. Push the **piston assembly** ⑦2 and the **rod assembly** ⑦3 together against the **cam** ⑥4 so that both cam bearings has contact with the **cam** ⑥4. Do not push hard, the bearings should just make contact with the cam. Then tighten the **rod screw** ⑥0

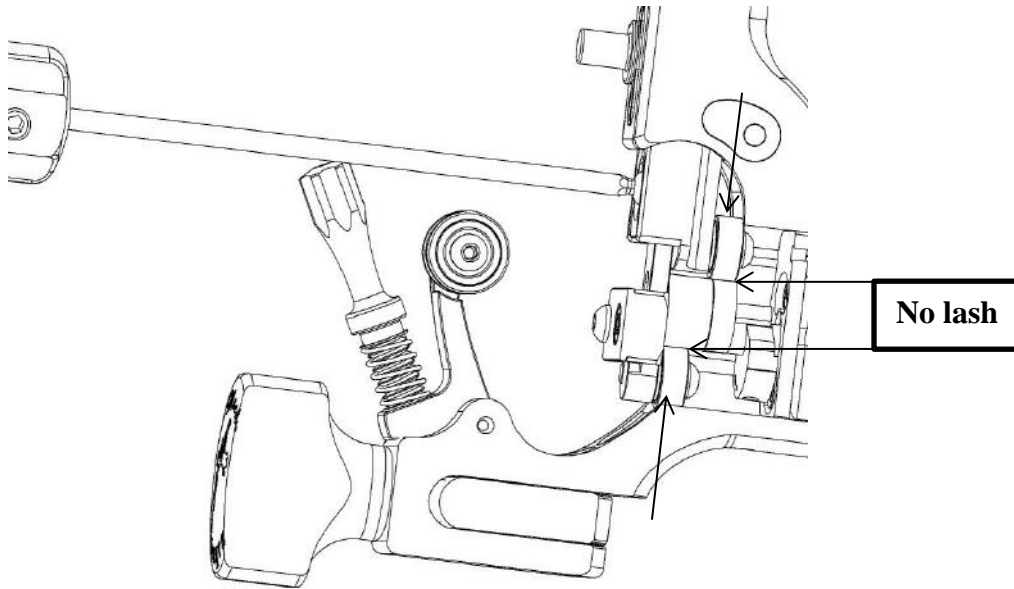

10. Run the machine around 9 volts to make sure everything runs smoothly.

Converting to cartridges

The Stingray X2 is fully compatible with cartridges and is easier to convert than the previous model. When using cartridges the **Stay up spring 24** must be removed to prevent strain on the motor and to function properly. The X2 version has a lid in the frame that allows quick access to the Stay up spring. To properly convert we recommend the **Precision tool kit 60**.

Remove the Stay up spring by removing the Lid on the side of the frame. After removing the Stay up spring, put the lid and screw back in place. If you wish to use standard needles again put the stay up spring back. Use the short end of the 1.5mm Allen key to push and hold it in place. Put the lid back in position and keep some pressure on the lid while pulling the Allen key out. The stay up spring should engage so that it rests on the lid.

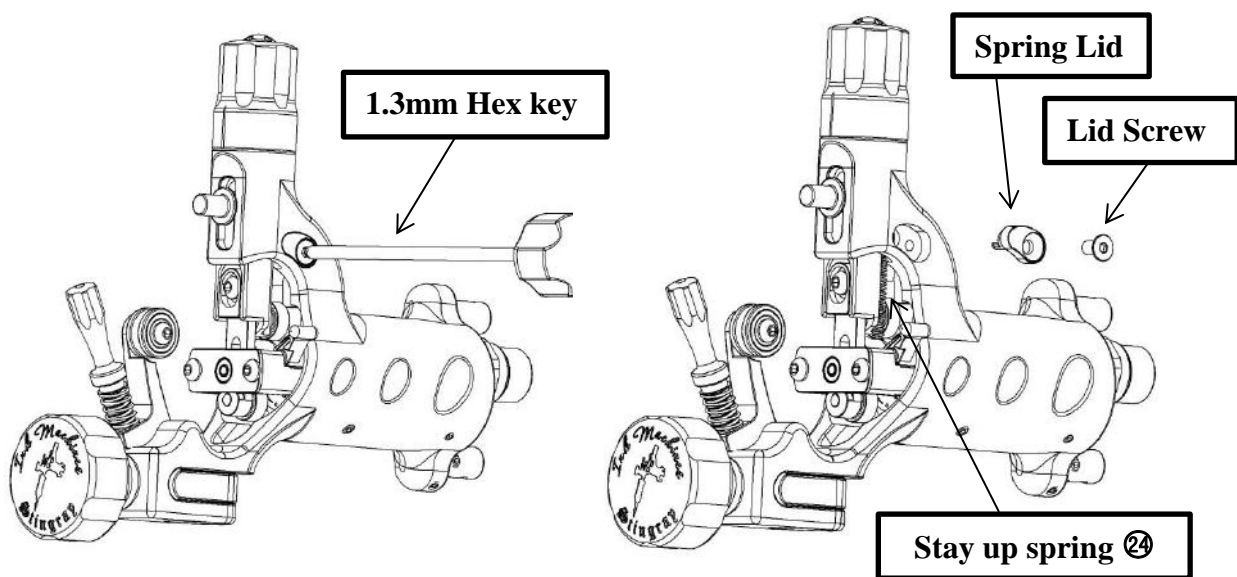

To take advantage of the give function when using cartridges the Inner piston spring should be replaced. If the give function is not required just adjust the give to the bottom position (hardest setting).

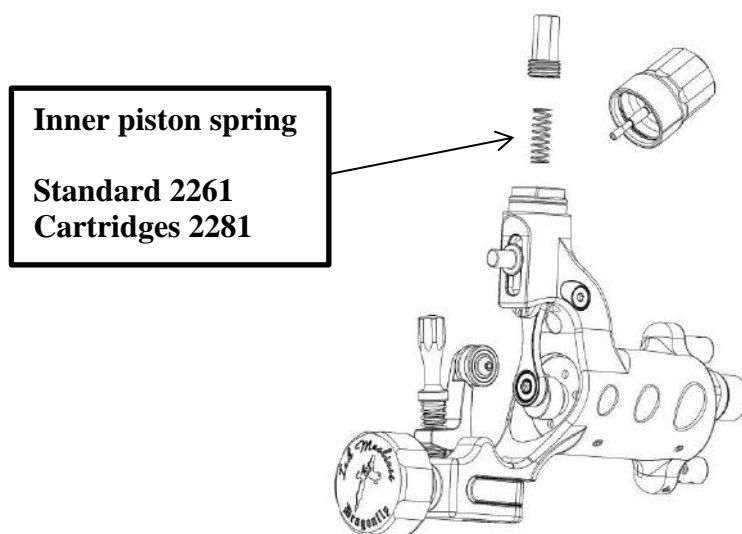

Maintenance instructions

Lubrication

Use the **oil 66** that were supplied with the machine and follow these steps to lubricate every 100 hours of use. Only use the oil provided with the machine, other oils may reduce lifetime of the machine and / or clog.

1. Remove grip and needle.
2. Remove the **cap 3B** and use the **Releaser 62** to release the **Piston assembly 72** while pushing the **Piston assembly 72** down to the bottom of its stroke. Lube with a small amount of oil in the corners between the piston and the **frame 1**. Put the **cap 3B** back in place by pushing and moving it in a circular motion.
3. Apply oil just above the needle bar pin in the oval hole.
4. Apply oil on the **bearings 30** of the **Needle bar retainer 44** and roll the bearings a few times back and forward to let the oil run into the bearings.
5. Apply oil between the **Bearing rod 71** and the **Shaft support 74**. No oil is required on the cam or the cam bearings.
6. Run the machine around 9 volts for about a minute and clean it when done.

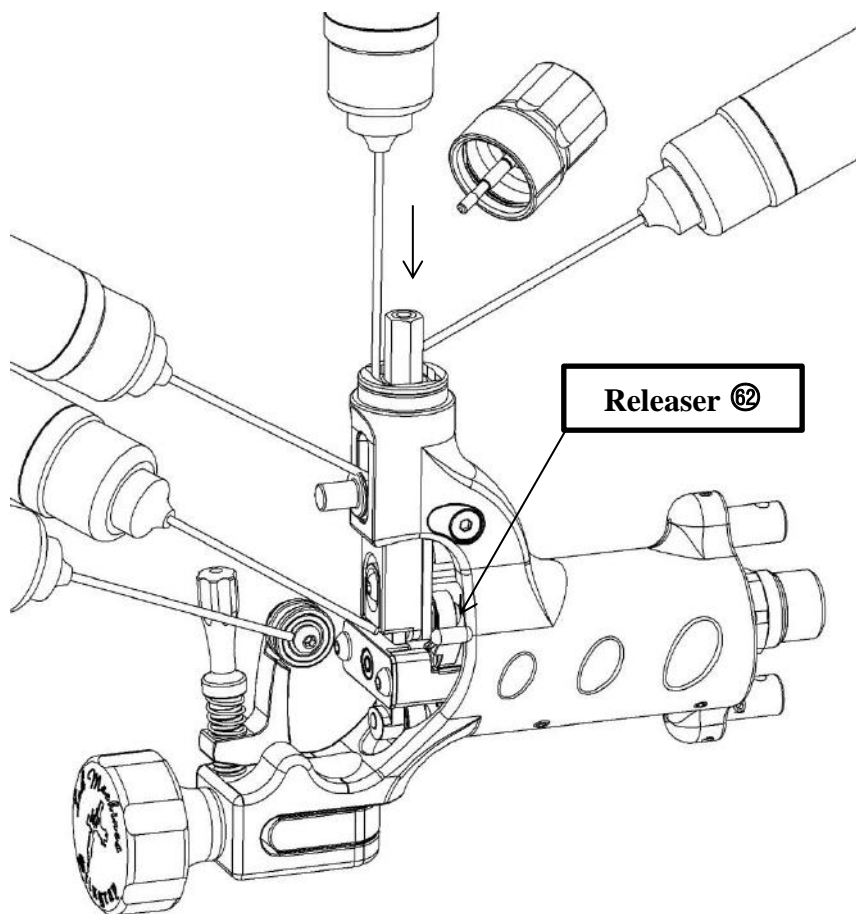

Wear components and replacement interval

Components estimated life in operating hours during normal use and given that maintenance instructions have been followed.

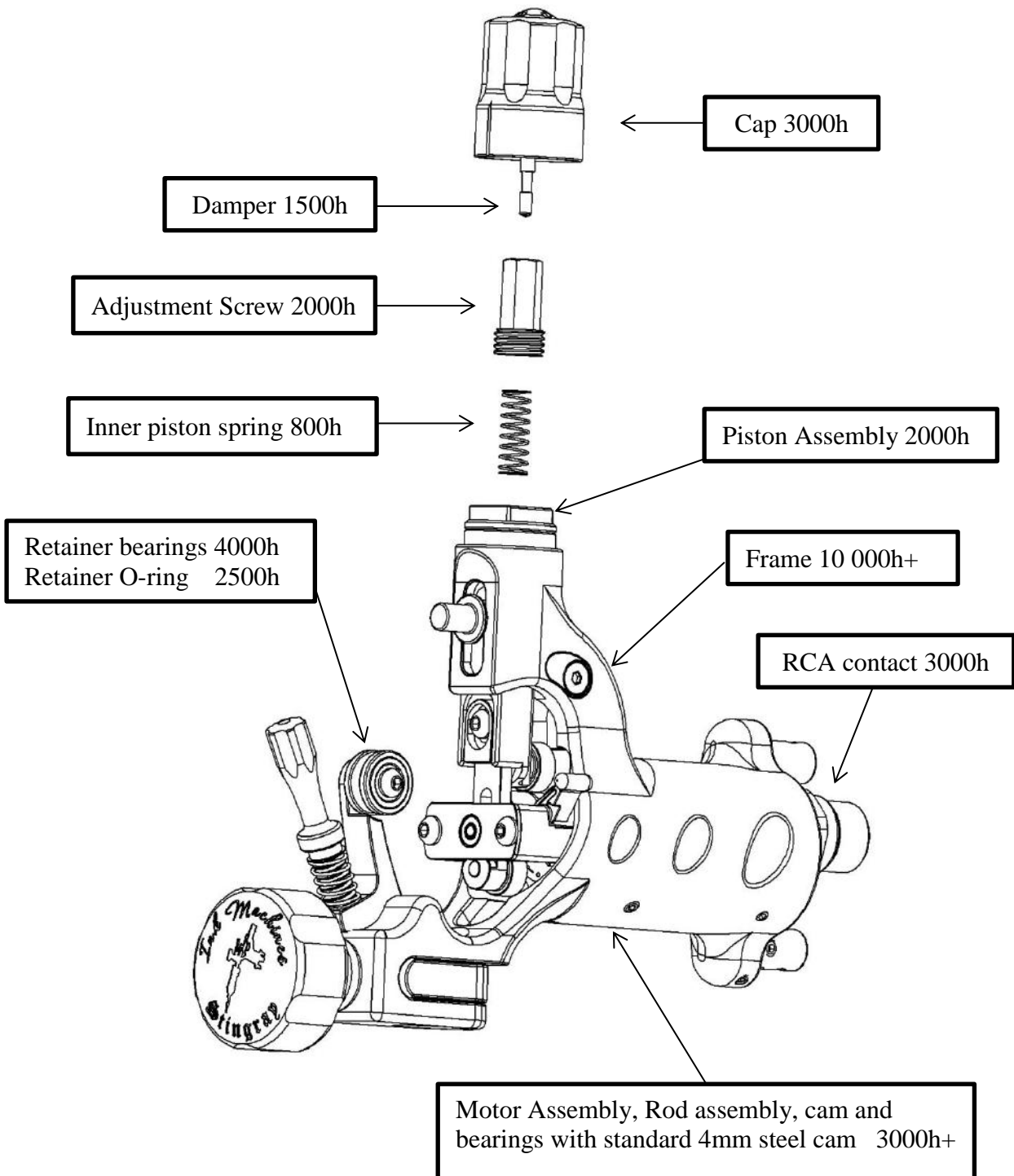

Troubleshooting guide

If you experience problems with the machine you can consult the troubleshooting guide or contact us for service at Inkmachines.com

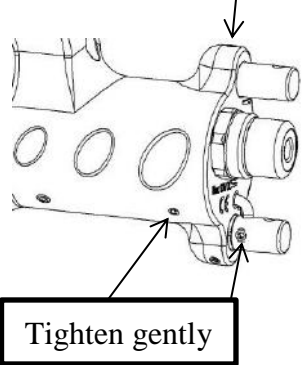
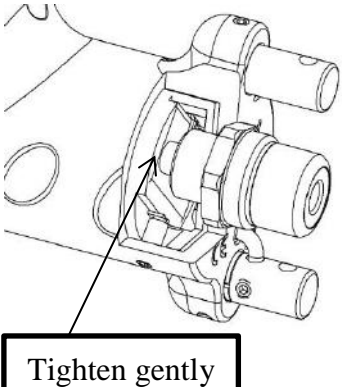
Symptom	Possible cause	Possible Solution
<p>The Motor ⑩ does not start when the power is on but the Cam ⑭ can be moved around without friction. (Electrical fault)</p>	<p>None or to low input voltage.</p> <p>Bad cable or power supply.</p> <p>Bad connection.</p>  <p>Bad connection between the RCA contact ⑫ and the motor.</p> 	<p>Increase voltage (max 13 volts).</p> <p>Make sure the power supply delivers the right current. Consult manual if necessary. Check clip cord or RCA cable. Replace if necessary.</p> <p>Make sure the contact screws are not loose, tighten the following: Contact screw motor negative (-) ⑩ Contact screw binding post negative (-) ⑮ Contact screw cord positive (+) ⑰.</p> <p>Loosen the RCA nut ⑬ and unscrew the RCA contact ⑫. Remove possible oxide by sanding the tip of the contact that engages with the contact plate of the motor. Clean the contact plate (visible through the threaded hole) with alcohol on a cotton bud. Turn the RCA contact until the tip touches the contact plate gently. Tighten the nut gently also.</p>

Short circuit between **Frame ①** and **Clip cord binding post positive (+) ⑩**. The clip cord binding post positive is electrically isolated from the **Frame ①** with a plastic sleeve. If the sleeve fails short circuit will occur.

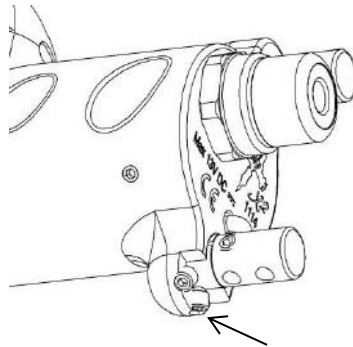

Remove the **Clip cord binding post positive (+) ⑩** and the sleeve. Replace if necessary.

The **Motor ⑦⑧** is defect.

Contact InkMachines for service.

Machine loses power and / or speed varies.

Friction between **frame ①** and **piston ⑥⑥**.

Lubricate according to maintenance instructions.

The **Needle bar pin ③** has moved and makes contact with the **frame ①**.

Relocate and tighten the **Needle bar pin**.

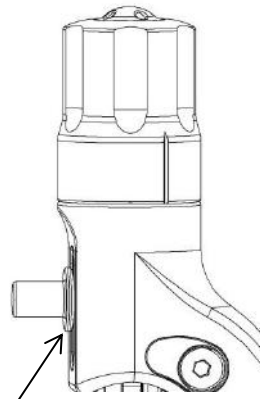

Needle bar retainer bearings ⑩ worn or clogged.

Needle bar retainer ④ to hard set against needle bar.

The **Cam** ④ is loose.

The **Stay up spring is broken** ②

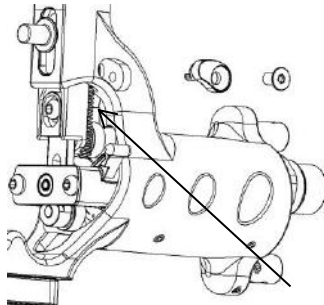

The **motor** ⑦⑧ is defect.

The machine or **pistons** are new. The suspension needs break in.

The **Needle bar pin** ⑥ is loose.

The **Inner piston** ⑩ is clogged.

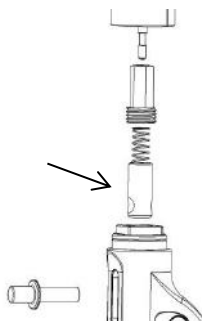

Clean and lubricate or replace ⑩.

Re-adjust. Just enough pressure to keep the needle stable should be applied.

Tighten the cam screw. See no 7. Of the cam change instructions.

Replace.

Contact InkMachines for service.

Lubricate and run the machine for a few minutes while holding the **Needle bar pin** ⑥ with your fingers and let the inner piston break in.

Relocate and tighten the **Needle bar pin**.

Remove the **Inner piston** ⑩. Clean and re-lubricate.

The needle suspension (give) is jammed or hangs up.

The **Needle bar pin ⑥** is wobbling and / or feels to loose. (A certain side to side play is normal).

The **Needle bar pin ⑥** is loose.

Relocate and tighten the **Needle bar pin**.

The **Inner piston spring ⑱** is defect.

Replace. Or stretch.

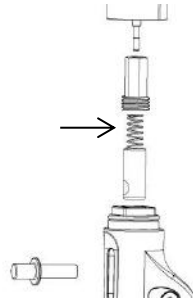

Too much play between the **Piston ⑳** and the **Inner piston ㉑**. (worn out).

Contact InkMachines for service.

The **Needle bar pin ⑥** suspension (give) is out of sync with the **piston ㉑** movement.

The **Inner piston ㉑** needs lubrication.

Lubricate.

The **Inner piston spring ⑱** is defect or fatigue.

Replace or stretch the existing spring.

The **Motor ㉒** loses power in a certain angle but will start when helped.

The **Motor ㉒** is defect.

Contact InkMachines for service.

The needle stops in random position and not in its upper position like it should.

The **Cap ③⑥** pops off or unscrews itself during tattooing.

The Machine runs with a “wobbling” sound or uneven sound.

The **Stay up spring ⑳** is broken.

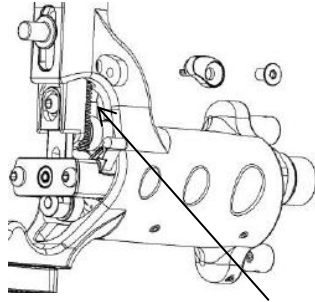

The hexagon of the **Adjustment screw ⑱** is damaged and pivots inside without the cap following.

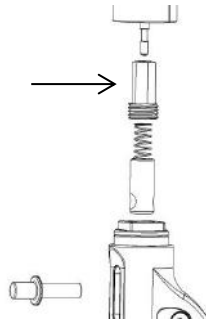

The spring inside the **Cap ③⑥** is too weak and won't keep the cap from turning by normal vibrations.

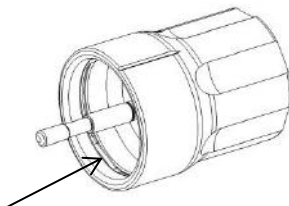

The needle bar retainer O-ring is not round.

Replace.

Remove the **Cap** and replace the **Adjustment screw ⑱**

Replace the **Cap ③⑥**

Replace the O-ring or put a drop of oil in the groove between the O-ring and the needle bar.

The **Needle bar retainer assembly** ④ vibrates loose during tattooing.

Ink is creeping up the needle bar.

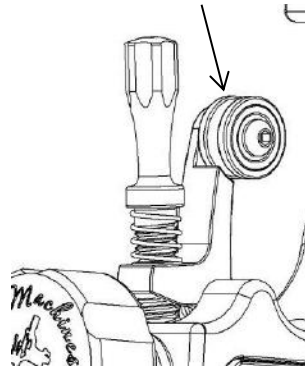

The **Retainer screw spring** ②⑧ is too weak.

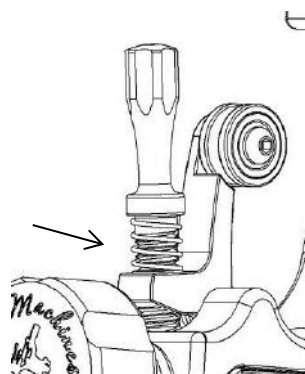

The pigment is thick. Thicker pigments tend to climb easier than thin pigments.

The needle has a long resting area (distance) in the tip.

A certain frequency (speed) makes it worse.

The needle has a tight fit in the tip.

Needle bar retainer ④ to hard set against needle bar.

Replace the **Retainer screw spring** ②⑧ Or stretch it.

Dilute the pigment.

Bend the needle at the solder so that only the tip of the needle rests against the tip or as little as possible.

Change the voltage up or down.

Try different needle and tip combinations.

Re-adjust. Just enough pressure to keep the needle stable should be applied.







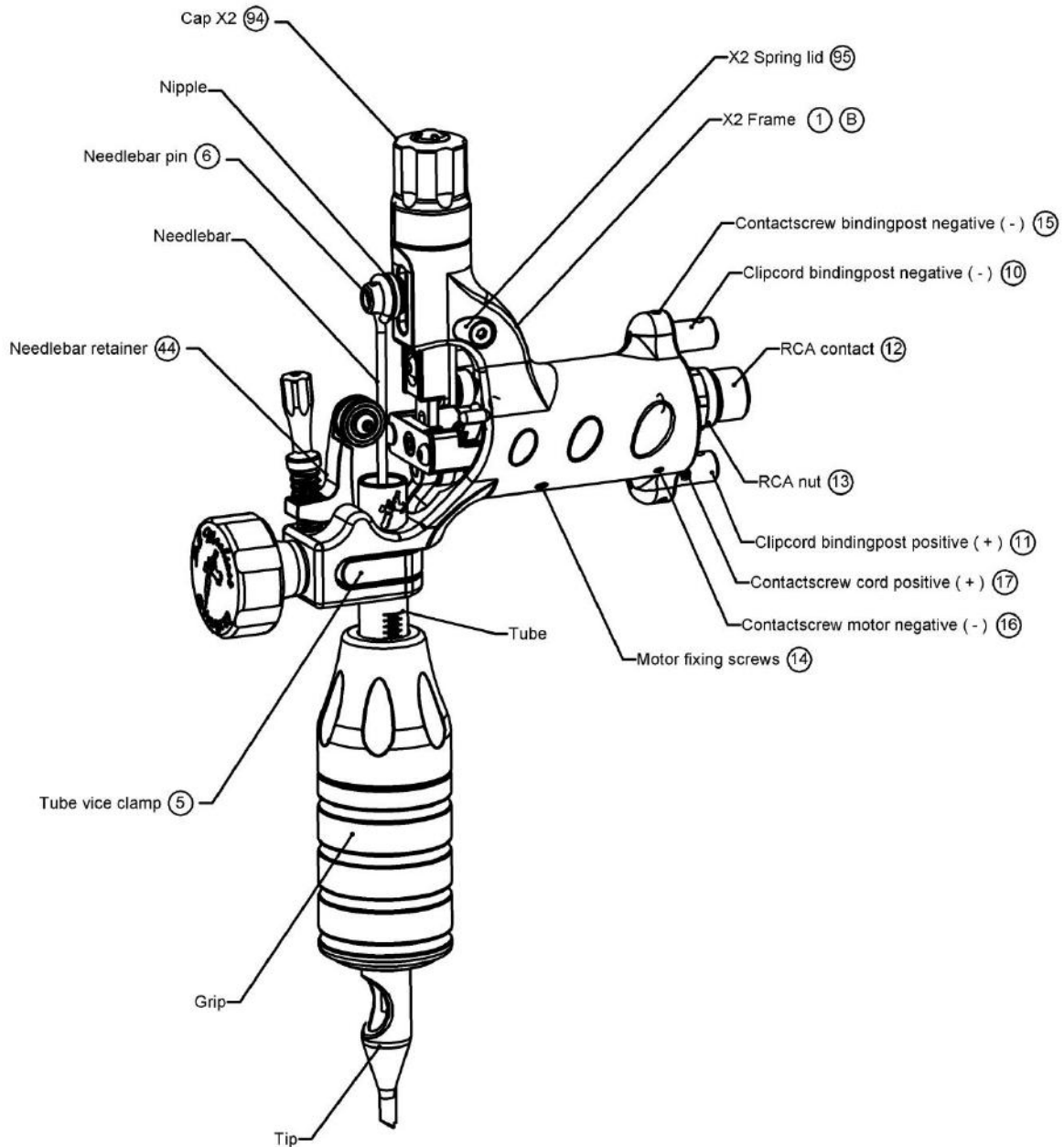

Specifications

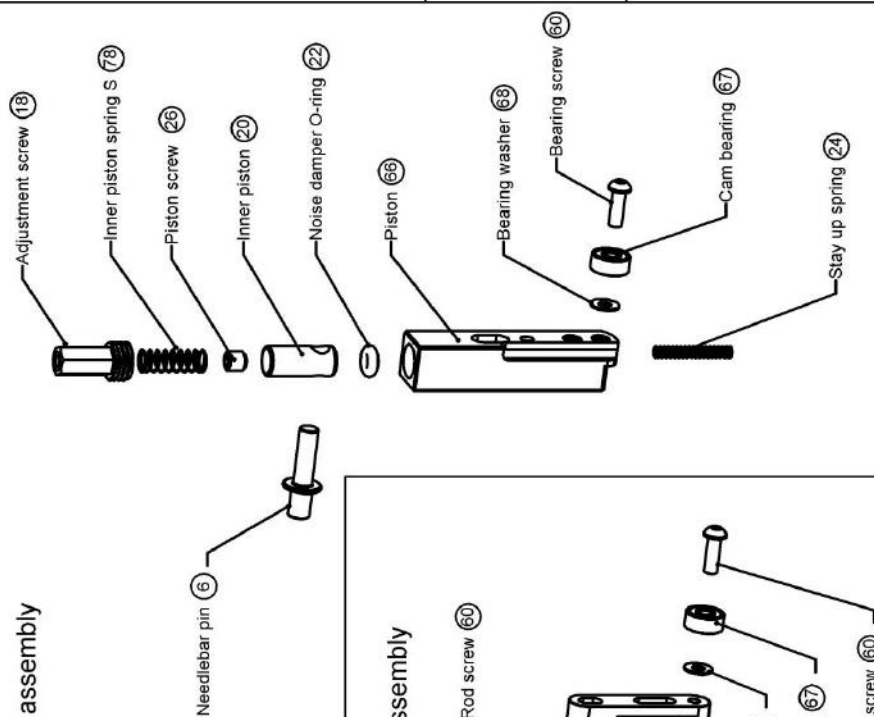
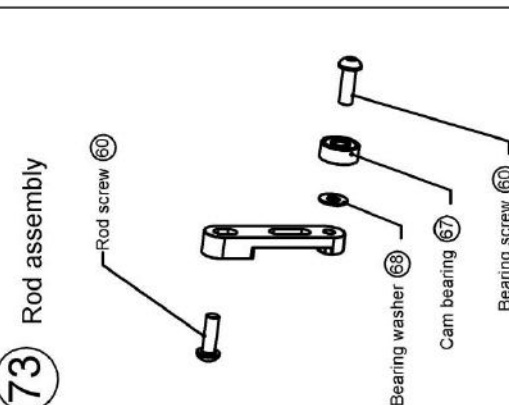
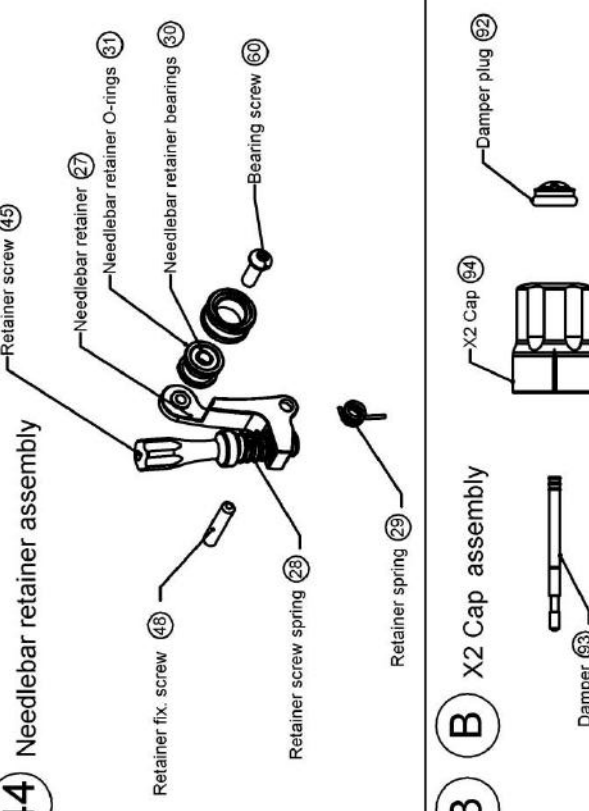
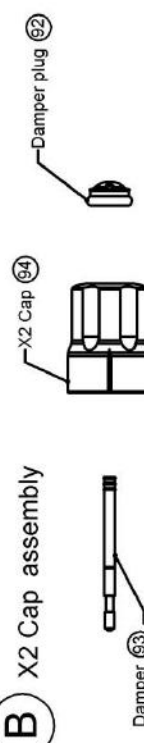
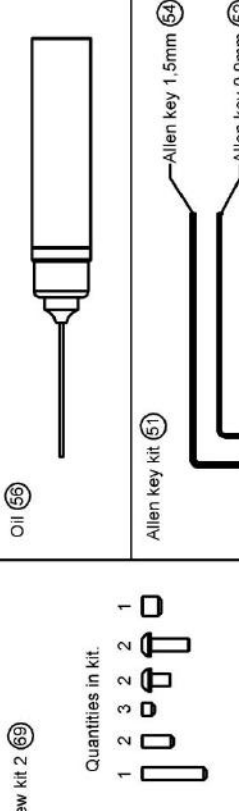
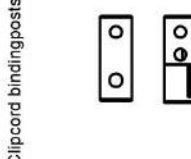
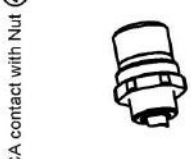
Input voltage	0 - 13 volt DC (max. 13 volt DC)
Power connections	RCA or clip cord (max. clip cord end diam Ø1,6 mm)
Rpm range	0 - 8 000 rpm / min
Stitches / sec	0 - 130 / sec
Stroke length	2.6-4mm depending on cam used. 4mm is standard
Suspension stroke (give)	0 - 2 mm
Max. tube diam Ø	Ø8 mm
Max. needle size	50 magnum
Weight	85 grams
Wireless ready	Yes
Dimensions LxBxH	95 x 21 x 77 mm

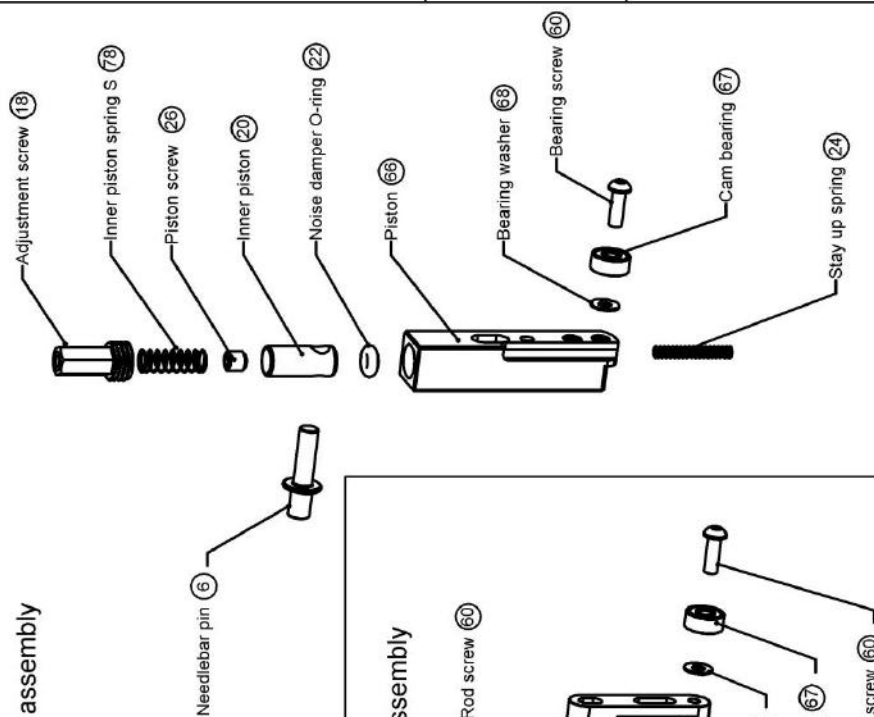
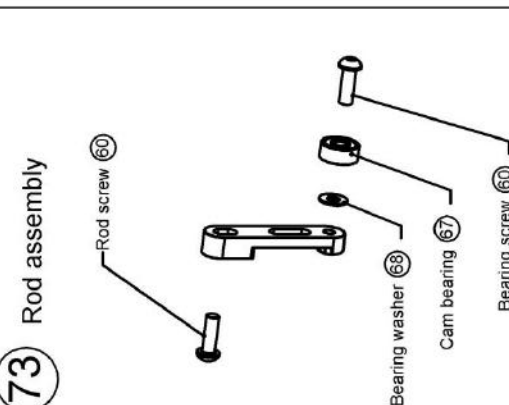
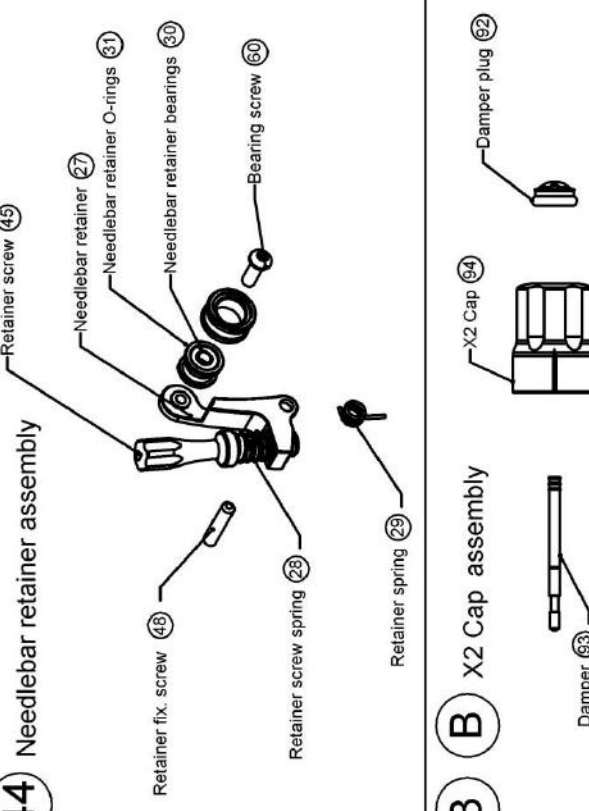
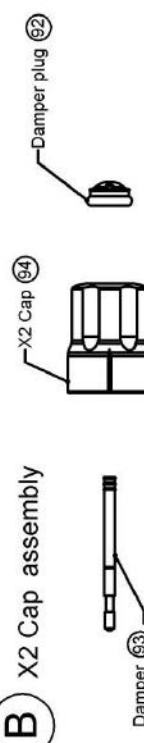
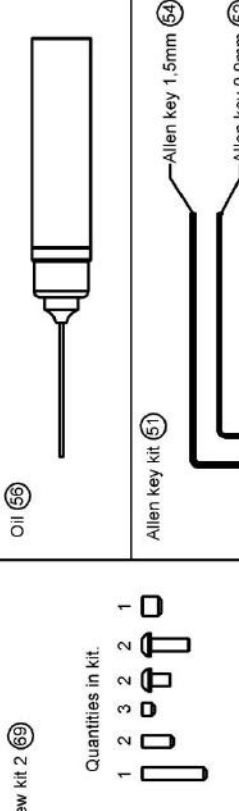
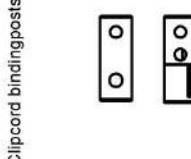
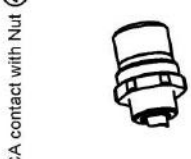
Part names

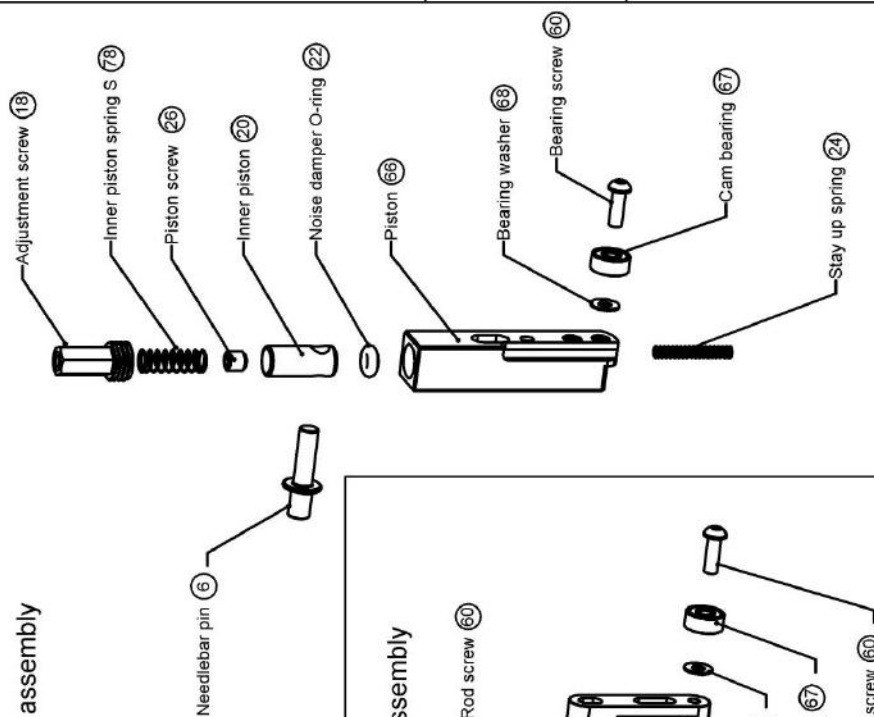
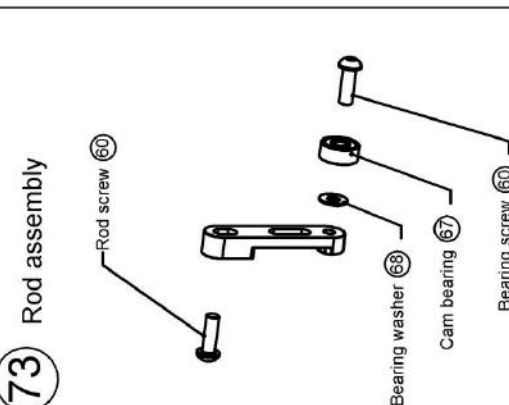
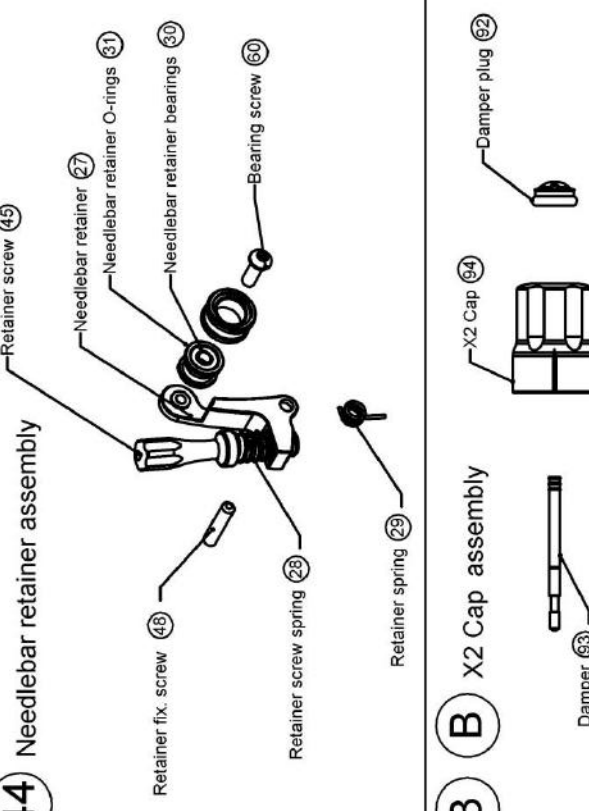
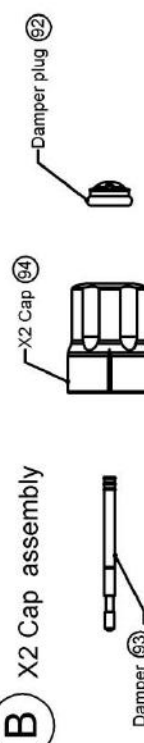
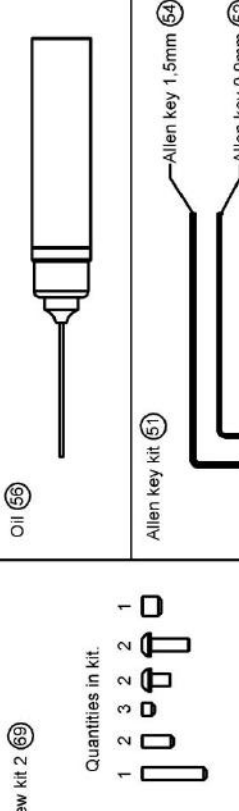
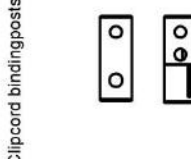
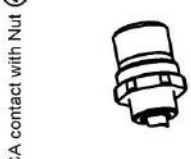
Note: Parts without numbers are not included in the purchase.

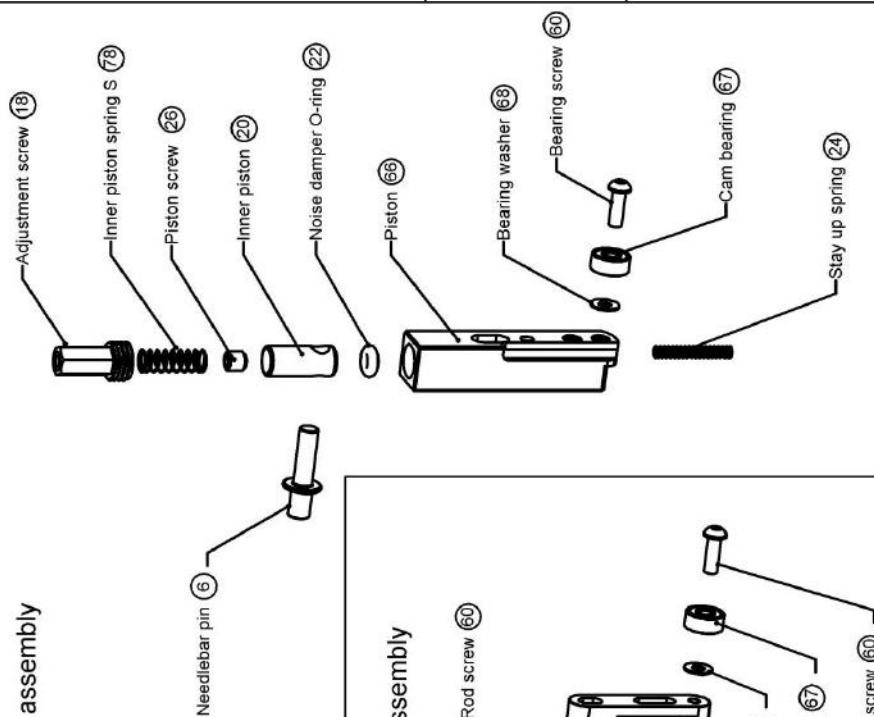
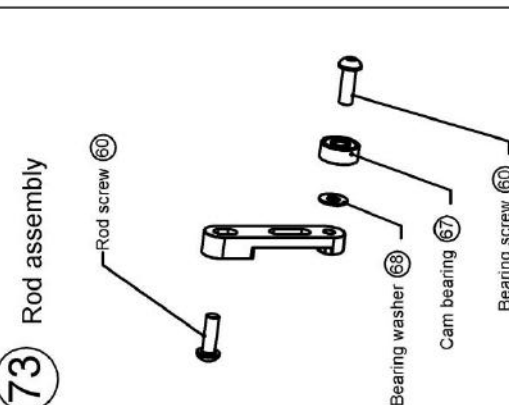
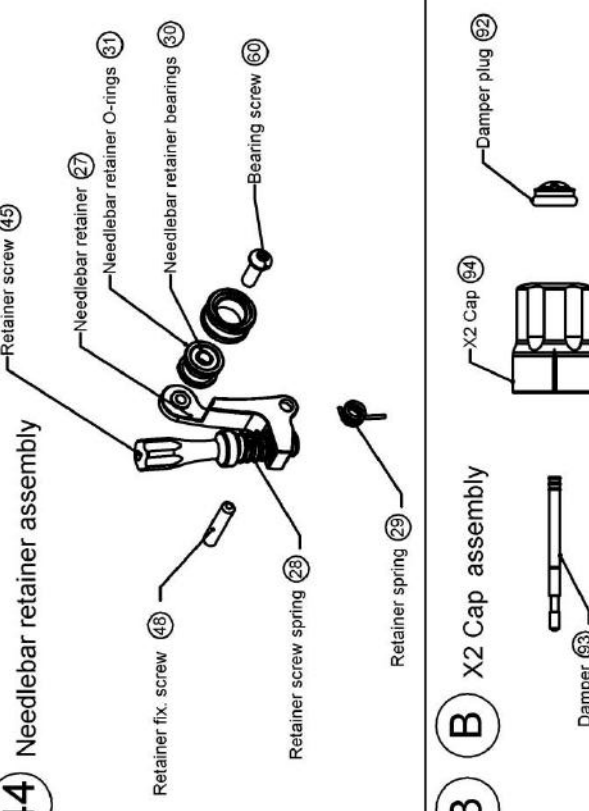
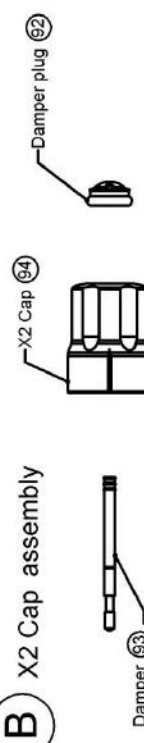
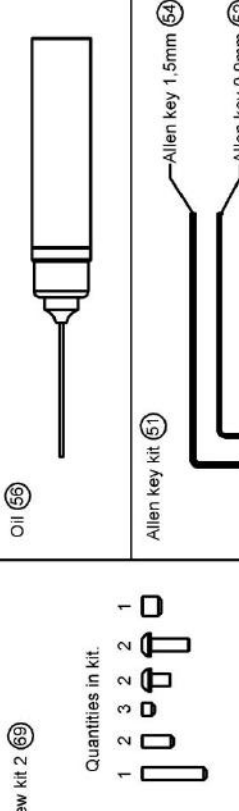
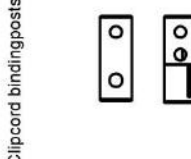
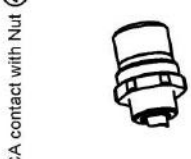

<p>72 Piston assembly</p> 	<p>73 Rod assembly</p> 	<p>44 Needlebar retainer assembly</p> 	<p>3 X2 Cap assembly</p> 	<p>Screw kit 2 (69)</p> <p>Quantities in kit:</p> <table border="1"> <tr> <td>1</td> <td>2</td> <td>3</td> <td>2</td> <td>2</td> <td>1</td> </tr> </table> 	1	2	3	2	2	1	<p>Clipcord bindingposts (47)</p>  <p>RCA contact with Nut (46)</p>  <p>Circlip pliers (55)</p> 
1	2	3	2	2	1						
<p>72 Piston assembly</p> 	<p>73 Rod assembly</p> 	<p>44 Needlebar retainer assembly</p> 	<p>3 X2 Cap assembly</p> 	<p>Screw kit 2 (69)</p> <p>Quantities in kit:</p> <table border="1"> <tr> <td>1</td> <td>2</td> <td>3</td> <td>2</td> <td>2</td> <td>1</td> </tr> </table> 	1	2	3	2	2	1	<p>Clipcord bindingposts (47)</p>  <p>RCA contact with Nut (46)</p>  <p>Circlip pliers (55)</p> 
1	2	3	2	2	1						
<p>72 Piston assembly</p> 	<p>73 Rod assembly</p> 	<p>44 Needlebar retainer assembly</p> 	<p>3 X2 Cap assembly</p> 	<p>Screw kit 2 (69)</p> <p>Quantities in kit:</p> <table border="1"> <tr> <td>1</td> <td>2</td> <td>3</td> <td>2</td> <td>2</td> <td>1</td> </tr> </table> 	1	2	3	2	2	1	<p>Clipcord bindingposts (47)</p>  <p>RCA contact with Nut (46)</p>  <p>Circlip pliers (55)</p> 
1	2	3	2	2	1						
<p>72 Piston assembly</p> 	<p>73 Rod assembly</p> 	<p>44 Needlebar retainer assembly</p> 	<p>3 X2 Cap assembly</p> 	<p>Screw kit 2 (69)</p> <p>Quantities in kit:</p> <table border="1"> <tr> <td>1</td> <td>2</td> <td>3</td> <td>2</td> <td>2</td> <td>1</td> </tr> </table> 	1	2	3	2	2	1	<p>Clipcord bindingposts (47)</p>  <p>RCA contact with Nut (46)</p>  <p>Circlip pliers (55)</p> 
1	2	3	2	2	1						



Declaration of Conformity

Manufacturer

InkMachines Sweden AB
Box 8025
350 08 Växjö
Sweden

Equipment

Tattoo machine Stingray X2
Year of manufacturer 2014

We InkMachines Sweden AB hereby declare that the Stingray tattoo machine specified above conforms with the following directives:

Machine Directive 2006/42/EC

Växjö 2010-05-07

.....

Christian Johansson CEO

Ink Machines Sweden AB
Org nr: 556807-7225
<http://www.inkmachines.com>

Box 8025
350 08 Växjö
Sweden